



Miniaturized and improved method for Apparent Total N-Nitroso Compounds determination in beer

Tomáš Vrzal¹*, Michaela Malečková^{1,2}, Jana Olšovská¹

¹ Research Institute of Brewing and Malting, Lípová 511/15,
120 00, Prague 2, Czech Republic

² Charles University, Faculty of Science, Department of Analytical
Chemistry, Albertov 6, 128 43, Prague 2, Czech Republic

*Corresponding author: tomas.vrzal@beerresearch.cz

Abstract

A miniaturized and improved method for Apparent Total Nitroso Compounds determination in liquid matrices was developed. The main improvement is based on a miniaturized and modified apparatus for chemical denitrosation of nitroso compounds by hydrogen bromide in a glacial acetic acid mixture. The reaction is carried out in a teflon reaction coil while the reaction product, gaseous nitric oxide, is drifted to a chemiluminescence detector by the flow of argon together with a vacuum obtained by the detector's oil pump. The apparatus significantly increased the efficiency of the Apparent Total N-Nitroso Compounds determination (compared to the previous method), specifically, the dead volume of the apparatus was significantly decreased, and the effect of the reverse reaction was eliminated as well. The apparatus shortens the analysis time (1.4 min/injection), further it provides a lower detection limit (3 µg(N-NO)/l), quantification limit (10 µg(N-NO)/l), and method uncertainty (15%), and is simpler for the operation.

Keywords: nitrosamines, nitroso compounds, ATNC, chemiluminescence detection, miniaturization

1 Introduction

N-Nitrosamines, especially volatile ones, are highly toxic substances occurring in lots of food and beverages, as well as in plastics, rubbers, and paints. Their concentrations in beer are usually lower than 0.2 µg/kg (Vrzal and Olšovská, 2016), and the most frequently detected N-nitrosodimethylamine (NDMA) mostly originated from malt. However, non-volatile N-nitrosamines are not generally known (except N-nitrosoproline) and their occasional occurrence in beer is obvious from Apparent Total N-Nitroso Compounds (ATNC) determination, sometimes referred to as Total N-Nitrosamines – TONO (Piazzoli et al., 2018; Kulshrestha et al., 2010), where most of the ATNC content is attributed to the non-volatiles (Čulík et al., 2012). Therefore, ATNC determination has still great importance in the beer quality/contamination monitoring process.

The original method for ATNC determination was proposed by Walters et al. (1983) and was based on chemical denitrosation of an N-nitroso group by a hydrobromic ac-

id-acetic acid mixture. The reaction usually takes place in a heated reaction flask with a reverse Liebig condenser. The formed gaseous product (nitric oxide and/or nitrosyl bromide) is then washed by hydroxide solutions, further cleaned by condense traps, and detected by the Nitrogen Chemiluminescence Detector (NCD; named also as Thermal Energy Analyzer (TEA) in the past). The whole procedure is performed in a glass apparatus under an inert gas atmosphere, see Figure 1. Since the original procedure is associated with many disadvantages and practical difficulties, few modified methods of that analysis were developed. Some of these drawbacks are high dead volume that results in long analysis time, low throughput, excessive peak tailing, difficult operation, and negatively increasing influence of the reverse reaction and water content to the peak shape and limit of detection across the analysis batch. Most of the modified procedures use apparatus which are easier to operate with, use a lower amount of chemicals, and/or different

principle of denitrosation (Breider and von Gunten, 2017). However, a comparison of their denitrosation mechanism and knowledge regarding selectivity reveals considerable doubt whether the original and the modified methods determine the same compounds in the analyzed sample (critical mainly in the fields where the original method is considered as a standard and is used for a routine quality-check). For these reasons, we decided to improve the original method while preserving the original principle.

The aim of this study is to develop and validate an improved method for ATNC determination in beer. The major improvement lies in the miniaturization and modification of the apparatus used for the ATNC determination resulting in the efficiency increase of the method, and lowering the quantitation limit and uncertainty.

2 Material and methods

Chemicals

Used chemicals are as follows: 33% hydrogen bromide in glacial acetic acid (Merck), *N*-nitrosodimethylamine

(100 µg/ml in methanol, Agilent Technologies), *N*-nitrosoproline (100 µg/ml, Isconlab, Germany), potassium hydroxide (Penta, Czech Republic), ethyl acetate (≥ 99.5%, Honeywell), ammonium sulphamate (> 99%, Merck, Germany), sulphuric acid (96%, Merck, Germany), methanol (≥ 99.9%, Honeywell), hydrochloric acid (37%, Merck, Germany), dry ice (Linde), deionized water (prepared by MilliQ system).

The reaction mixture was prepared by mixing 60 ml of ethyl acetate (with 1 g/l ammonium sulfamate) with 40 ml of 33% hydrogen bromide solution in glacial acetic acid. The reaction mixture was held in a closed flask and always freshly prepared before the analysis run.

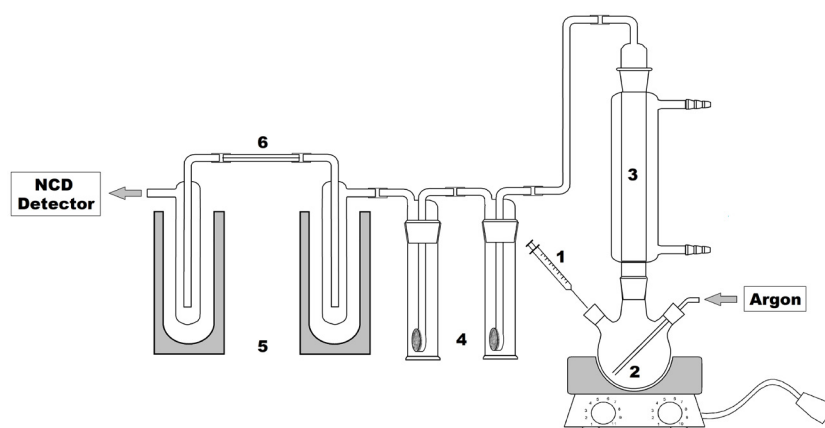

Figure 1 Original apparatus for ATNC determination; 1 – syringe; 2 – reaction flask; 3 – Liebig condenser; 4 – gas washing bottles; 5 – condense traps; 6 – capillary restriction

Instrumentation

The miniaturized apparatus (Figure 2) for ATNC determination consists of an injection port (1), reaction coil (2), Liebig condenser (3), stock flask (4), gas washing bottle (5), two condense traps (6), and capillary restriction (7).

The injection port (Figure 3) is made up of a little flask with a frit and screw cap with a septum. Argon as carrier gas (AirProducts, Czech Republic) is supplied to the apparatus by an injection needle connected to a rotameter by a teflon tubing. The injection port is connected to the reaction coil by a plastic valve (designed by the manufacturer for the flow regulation during the solid-phase extraction). The reaction coil (Figure 4) is formed by a teflon tube

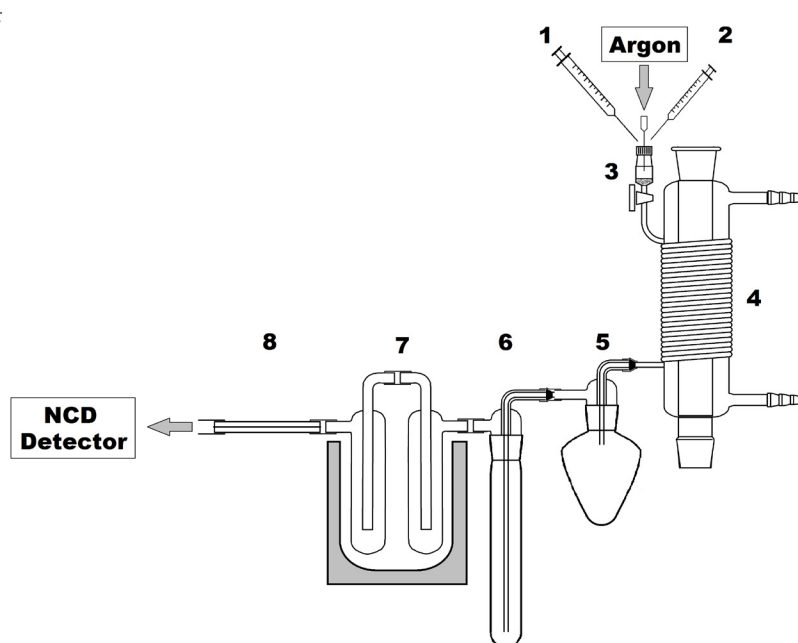

Figure 2 Scheme of the miniaturized apparatus; 1 – syringe with reaction mixture; 2 – syringe with sample; 3 – injection port; 4 – reaction coil; 5 – stock flask; 6 – gas washing bottle; 7 – condense traps; 8 – capillary restriction

ing (275 cm length, 1.5 mm ID, 3.2 mm OD, Supelco) coiled on the external wall of the Liebig condenser. Water at approximately 60 °C is pumped into the condenser by the flow thermal block to maintain appropriate conditions for the denitrosation reaction. The tubing is connected to the stock flask (Figure 5) consisting of a 50 ml heart-shaped flask, gas washing adapter (without an inner glass tube), and reducing adapter. The tubing from the reaction coil comes up to the neck of the heart-shaped flask. The gas washing bottle filled with 12 ml of 33% potassium hydroxide solution (Figure 5) is formed by a test tube, gas washing adapter (without an inner glass tube), and teflon tubing (reaching the bottom of the test tube). The two condense traps (20 × 100 mm) are asymmetrically connected together, immersed in chilled methanol (by dry ice) in Dewar's vessel, and connected to the capillary restriction (180 mm length, 0.32 mm ID), see Figure 6. Individual parts of the apparatus are connected by a Tygon® tube (1/4 and 13/16 " ID). The teflon tubes are sealed by metal ferrules. All connections have to be gas-tight.

The apparatus is connected to the Nitrogen Chemiluminescence Detector (NCD 8255, Agilent Technologies, Santa Clara, USA) through the capillary restriction by teflon tubing. The reaction chamber of the detector is chilled for -10 °C. Oxygen (AirProducts, Czech Republic) is used for ozone generation in the detector. The working pressure in the chamber is between 5–8 torr.

Analysis procedure

A beer sample was prepared for analysis by the following procedure. Five millilitres of a beer sample were mixed with 1 ml of ammonium sulfamate (0.2 mol/l) in 0.2 mol/l sulphuric acid and left to react for 15 minutes. Meanwhile, an SPE column (Bond Elux SAX, 500 mg) was conditioned by 3 ml of methanol and 3 ml of hydrochloric acid solution (0.01 mol/l). Then, the



Figure 3 Photo of the injection port
Figure 4 Photo of the reaction coil
Figure 5 Photo of the stock flask and gas washing bottle
Figure 6 Photo of the condense traps and capillary restriction

sample was loaded on the SPE column and the first 2 ml of eluate were discarded, the remaining eluate was collected and analyzed. Deionized water was used as a blank sample – prepared by the same procedure.

The apparatus is prepared according to the procedure in the previous section. The flow of argon is firstly maintained at 100 ml/min, and, after connecting the apparatus to the detector, the flow is reduced in order to have the total flow at rotameter between 20–60 ml/min. Firstly, an apparatus conditioning by the reaction mixture is performed as follows – the plastic valve is closed, 200 µl of ethyl acetate is injected into the injection port and 1 ml of the reaction mixture is subsequently injected, the plastic valve is opened and approximately 300 µl of water is injected (for system flushing and peak focusing). This procedure is repeated three times. Subsequently, injection of NDMA solution (200 µg/l in ethyl acetate) is carried out (the same procedure as previously described for conditioning, except ethyl acetate injection). Injection can be repeated when a signal of the detector is back at a baseline level. Injection is repeated until peak areas of two consecutive NDMA injections are not significantly different. After these preliminary steps, the system is ready for the analysis itself. The analysis is carried out by a sequence of injections (injection procedure described above): NDMA solution, blank sample, sample, NDMA solution (each injection two times). Analysis can be repeated until the stock flask is full.

ATNC quantitation is performed by a sample peak area comparison with the peak area of NDMA, according to Equation 1.

$$x = \frac{A_s}{A_{NDMA}} \cdot \frac{M_{N-NO}}{A_{NDMA}} \cdot \frac{6}{5} \cdot k \quad \text{Equation 1}$$

Where x is Apparent Total N -Nitroso Compounds concentration in µg(N-NO)/l, A_s is a peak area of a sample, A_{NDMA} is a peak area of NDMA standard solution, M_{N-NO} is a molecular weight of N -nitroso moiety (44 g/mol), M_{NDMA} is a molecular weight of N -nitrosodimethylamine (74 g/mol), k is a concentration of NDMA standard solution (200 µg/l).

Method validation

The method was validated according to the Eurachem guide (Magnusson and Örnemark, 2014; Ellison and Williams, 2012). The limits of detection and quantitation were evaluated by replicate measurements (10 times) of the reagent blank, and the obtained values were verified by repeated experiments in three days (spaced at least a week). Total recovery of the method was evaluated by analysis of a beer sample spiked with N -nitrosoproline at seven different concentrations (0, 11, 32, 54, 75, 96, 118 µg(N-NO)/l) together with a comparison of deter-

mined concentrations in real samples by the original method. Linearity in this range of concentrations was also checked. Expanded uncertainty of the determined concentrations ($k = 2$) was evaluated by Monte Carlo simulation (100 000 repetitions) using the *MonteCarlo* package (v 1.0.6) (Leschinski, 2019) in RStudio (v 4.0.1). The simulation was based on the uncertainty of concentration of NDMA certified reference standard (triangular distribution was used according to the Eurachem Guide (Ellison and Williams, 2012)), and experimentally determined standard deviation of repeated analysis of blank, NDMA standard and beer sample under conditions of reproducibility (normal distribution was used).

3 Results and discussion

The miniaturized apparatus was designed to eliminate the main disadvantages of the original ATNC method, e.g., high dead volume resulting in long analysis time, low throughput, peak tailing, difficult operation, and the negatively increased influence of the reverse reaction and water content on the peak shape and limit of detection across the analysis batch. These issues were solved by i) apparatus miniaturization and ii) replacement of the reaction flask by the reaction coil.

The first part of the apparatus – the injection port – is designed for injection and sample mixing with a reaction mixture. The denitrosation reaction takes place in a heated reaction coil and the injected liquid is collected in the stock flask. Hence, each newly injected sample/NDMA standard reacts with the reaction mixture in the reaction coil and is not in contact with reaction products of previous injections (e.g., dimethylamine from denitrosation of NDMA standard) which shift the reaction equilibrium. The reaction coil also prevents the reaction to take place in the environment with an excess of water from previous injections of a sample, since water significantly slows down the reaction rate. Therefore, the influence of the reverse reaction and water content on the method performance is eliminated. The gas washing bottle filled with hydroxide solution is intended for acidic vapour removal, and liquid droplets were condensed in the traps. The capillary restriction is used for a pressure reduction between the apparatus and detector.

The length of the reaction coil was optimized on basis of a continuous flow of the reaction mixture and sufficient reaction time/reaction yield. An excessively long reaction coil caused a slow flow, partial or total evaporation of the reaction mixture, and peak broadening. On the other hand, short reaction coils were insufficient due to a short contact of the reaction mixture with the heated

Liebig condenser resulting in low reaction yield. Hence, the final length (275 cm) was selected as optimal since fast and continuous flow, satisfactory reaction yield, and sharp peaks were provided.

The validation results (Table 1) exhibit an improvement of the miniaturized method for ATNC determination over the original method – lower limit of detection and quantitation, higher precision of the determined concentration together with comparable recovery. Furthermore, the miniaturized apparatus produces sharper peaks with decreased peak width which enables a higher amount of injections in a given time.

4 Conclusions

The improved method for ATNC determination in beer using miniaturized apparatus with improved functionalities enables use for routine analytical/quality control or research purposes with a high amount of samples as it eliminates the drawbacks of the original method. Therefore, this relatively high-throughput method saves money and time, and improves the performance of determination. On the other hand, the method still requires manual operation, and automatization would further improve its performance and usability.

5 Acknowledgement

This study was supported by the Technological Agency of the Czech Republic (program Zéta, TJ02000296) and by the Ministry of Agriculture of the Czech Republic within the institutional support MZE-RO1918.

Table 1 Comparison of the validation parameters of the miniaturized method for ATNC determination in beer with the original method

parameter	method	
	miniaturized	original
limit of detection [$\mu\text{g}(\text{N-NO})/\text{l}$]	3	6
limit of quantitation [$\mu\text{g}(\text{N-NO})/\text{l}$]	10	20
working range [$\mu\text{g}(\text{N-NO})/\text{l}$]	10–120	20–120
recovery [%]	101.40 \pm 14.13	~ 100
expanded uncertainty ($k = 2$) [%]	15	25
peak width at baseline [min]	1.4	10.5
possible injections per hour	~ 38	~ 6

6 References

- Breider, F., von Gunten, U. (2017). Quantification of total *N*-nitrosamine concentrations in aqueous samples via UV-photolysis and chemiluminescence detection of nitric oxide. *Analytical Chemistry*, 89(3), 1574–1582. <https://doi.org/10.1021/acs.analchem.6b03595>
- Čulík, J., Horák, T., Čejka, P., Jurková, M. (2012). Non-volatile *N*-nitrosamines in brewing industry, Part I. – Arrising and methods of estimation. *Kvasny prumysl*, 58(1), 6–12. <https://doi.org/10.18832/kp2012002>
- Ellison, S. L. R., Williams, A. (Eds.). (2012). *Eurachem/CITAC guide: Quantifying Uncertainty in Analytical Measurement* (Third edition). Retrieved from www.eurachem.org
- Kulshrestha, P., McKinstry, K. C., Fernandez, B. O., Feelisch, M., Mitch, W. A. (2010). Application of an optimized total *N*-nitrosamine (TONO) assay to pools: Placing *N*-nitrosodimethylamine (NDMA) determinations into perspective. *Environmental Science & Technology*, 44(9), 3369–3375. <https://doi.org/10.1021/es100361f>
- Leschinski, C. H. (2019). MonteCarlo: Automatic Parallelized Monte Carlo Simulations (Version R package version 1.0.6). Retrieved from <https://CRAN.R-project.org/package=MonteCarlo>
- Magnusson, B., Örnemark, U. (Eds.). (2014). *Eurachem Guide: The Fitness for Purpose of Analytical Methods – A Laboratory Guide to Method Validation and Related Topics* (Second edition). Retrieved from <http://www.eurachem.org>
- Piazzoli, A., Breider, F., Aquillon, C. G., Antonelli, M., Gunten, U. von. (2018). Specific and total *N*-nitrosamines formation potentials of nitrogenous micropollutants during chloramination. *Water Research*, 135, 311–321. <https://doi.org/10.1016/j.watres.2018.02.019>
- Vrzal, T., Olšovská, J. (2016). *N*-Nitrosamines in 21st century. *Kvasny prumysl*, 62(1), 2–8. <https://doi.org/10.18832/kp2016001>
- Walters, C. L., Hart, R. J., Smith, P. L. (1983). III.1.b Analysis of total *N*-nitroso compounds as a group by denitrosation to nitric oxide, with detection using a chemiluminescence analyser. *IARC Scientific Publications*, (45), 295–308.